

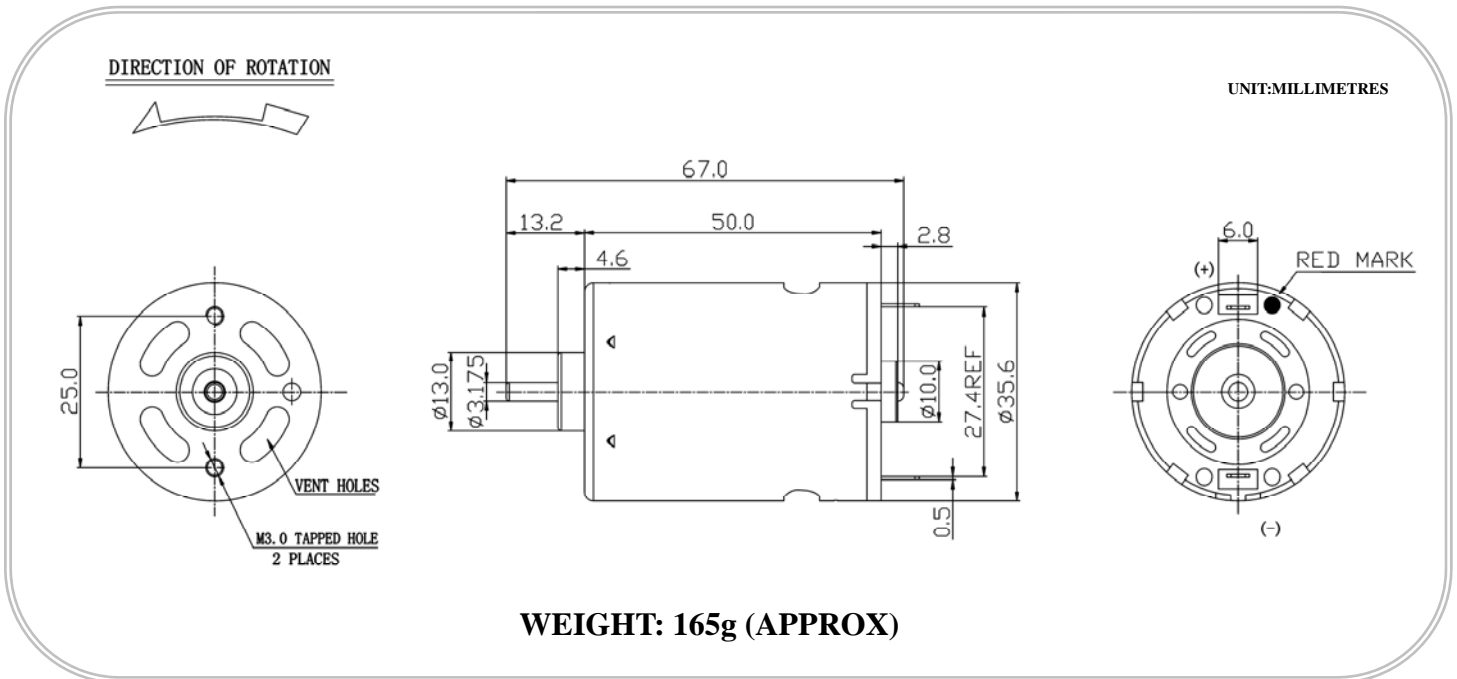

## TR540MSC series

- Typical Applications:
- Household Appliances
  - Vacuum Cleaner
  - Bilge Pump
- / Automotive Products
  - Car Accessory
  - Automatic Cruise Control
  - Lumbar Support



MODEL	VOLTAGE		NO LOAD		AT MAXIMUM EFFICIENCY				STALL		
	OPERATION RANGE	NOMINAL	SPEED	CURRENT	SPEED	CURRENT	TORQUE		TORQUE		CURRENT
			rpm	A	rpm	A	mN-m	g-cm	mN-m	g-cm	A
TR540MSC-23220	12~24V	18V CONSTANT	4950	0.172	4120	0.84	21.17	216	127.4	1300	4.2
TR545MSC-21102	24~48V	48V CONSTANT	15500	0.195	13500	1.34	30.38	310	240.1	2450	9.2