

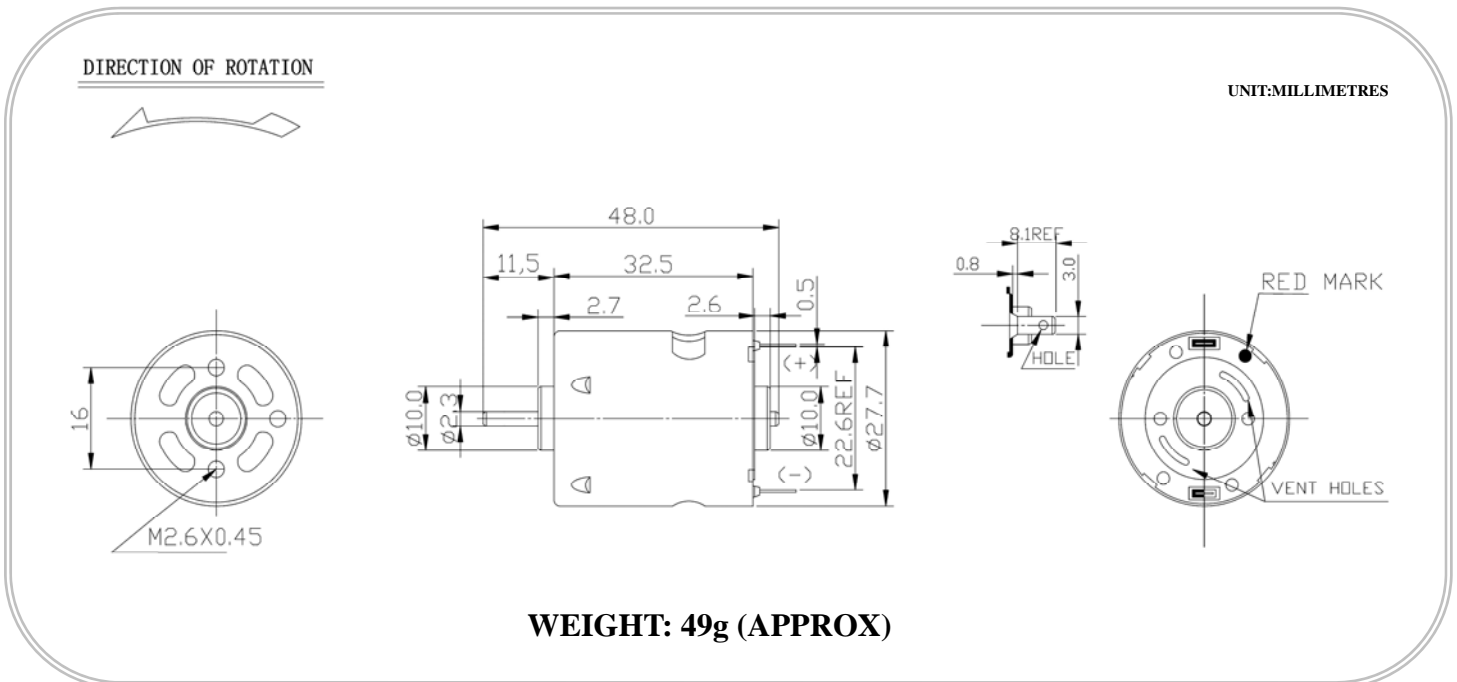

## TR360MSC series

- Typical Applications: Precision Instruments / Household Appliances  
 - Automatic Vending Machine - Tooth Brush  
 Office Automation Equipments  
 - Copy Machine



MODEL	VOLTAGE		NO LOAD		AT MAXIMUM EFFICIENCY				STALL		
	OPERATION RANGE	NOMINAL	SPEED	CURRENT	SPEED	CURRENT	TORQUE		TORQUE		CURRENT
			rpm	A	rpm	A	mN-m	g-cm	mN-m	g-cm	A
TR360MSC-10500	12~24V	24V CONSTANT	7000	0.035	5650	0.16	3.92	40.0	22.05	225	0.72
TR360MSC-2880	6.0~12V	7.2V CONSTANT	12500	0.260	10500	1.50	6.57	67.0	41.16	420	7.70
TR365MSC-16125	12~24V	12V CONSTANT	6900	0.110	5470	0.42	5.75	58.7	27.93	285	1.60