

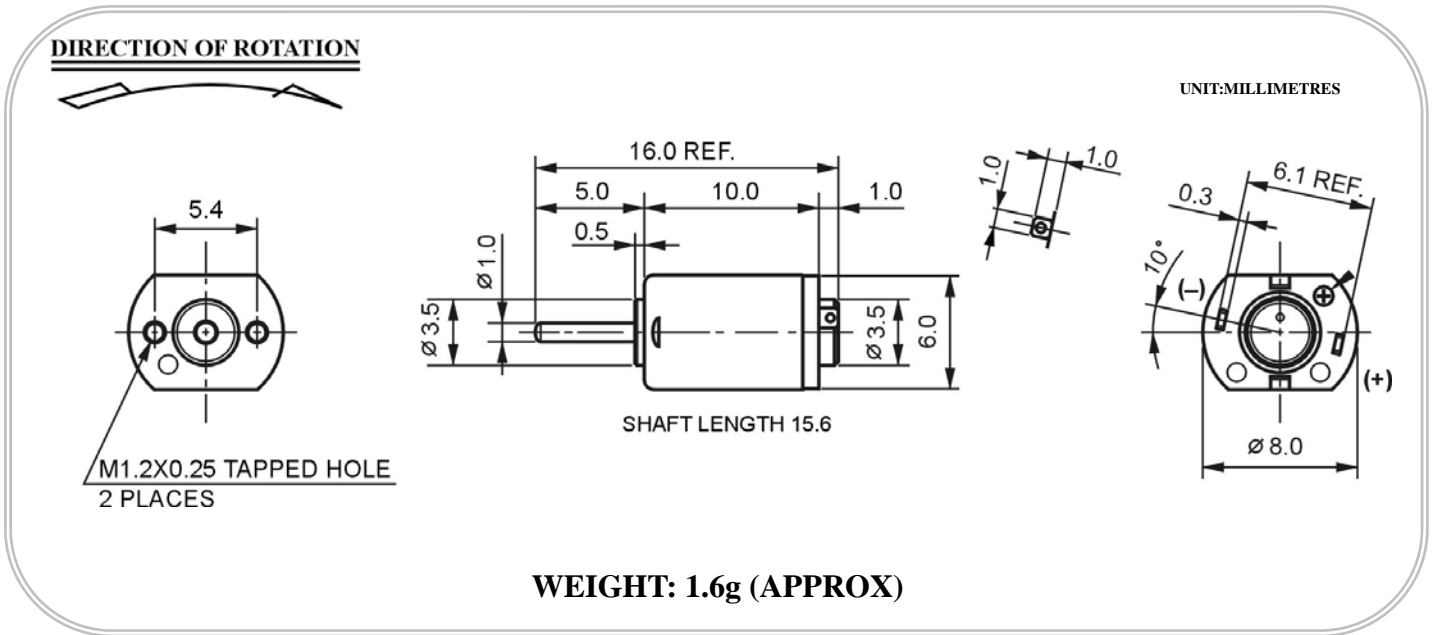

TFK10 series

Typical Applications: Office Automation Equipments
- Note Book PC

Precision Instruments
- Camera



MODEL	VOLTAGE		NO LOAD		AT MAXIMUM EFFICIENCY				STALL		
	OPERATION RANGE	NOMINAL	SPEED	CURRENT	SPEED	CURRENT	TORQUE		TORQUE		CURRENT
			rpm	A	rpm	A	mN-m	g-cm	mN-m	g-cm	A
TFK10-05215	1.5~4.5V	3.0V CONSTANT	12000	0.028	7360	0.044	0.08	0.8	0.20	2	0.07
TFK10-05240	3.0~6.0V	6.0V CONSTANT	39000	0.061	27300	0.145	0.09	0.9	0.29	3	0.34