



TF050 /C series

Typical Applications: Office Automation Equipments

- Printer
- Household Appliances
- Electric Shaver

Auto and Visual Equipments

- CD Player
- Car MD Player
- DVD Player

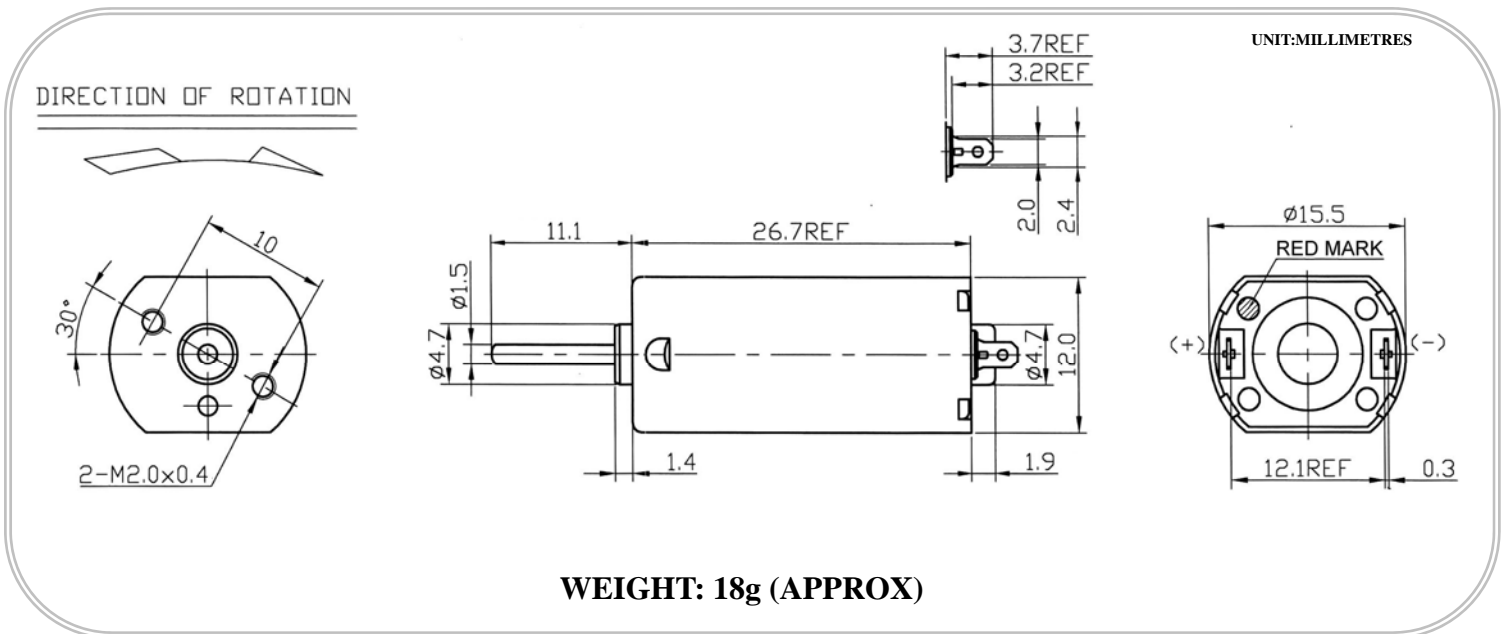

MODEL	VOLTAGE		NO LOAD		AT MAXIMUM EFFICIENCY				STALL		
	OPERATION RANGE	NOMINAL	SPEED	CURRENT	SPEED	CURRENT	TORQUE		TORQUE		CURRENT
			rpm	A			mN-m	g-cm	mN-m	g-cm	
TF050-08280	6.0~12V	12V CONSTANT	10000	0.026	8060	0.11	0.87	8.9	2.52	46	0.46
TF050-09230	6.0~12V	10V CONSTANT	10500	0.034	8470	0.14	0.95	9.7	4.90	50	0.59
TF050-13130	3.0~9.0V	9.0V CONSTANT	17500	0.094	14350	0.43	1.54	15.7	8.53	87	1.97
TF050C-2035	1.5~4.5V	4.5V CONSTANT	31000	0.430	24800	1.70	1.74	17.8	8.72	89	6.78