

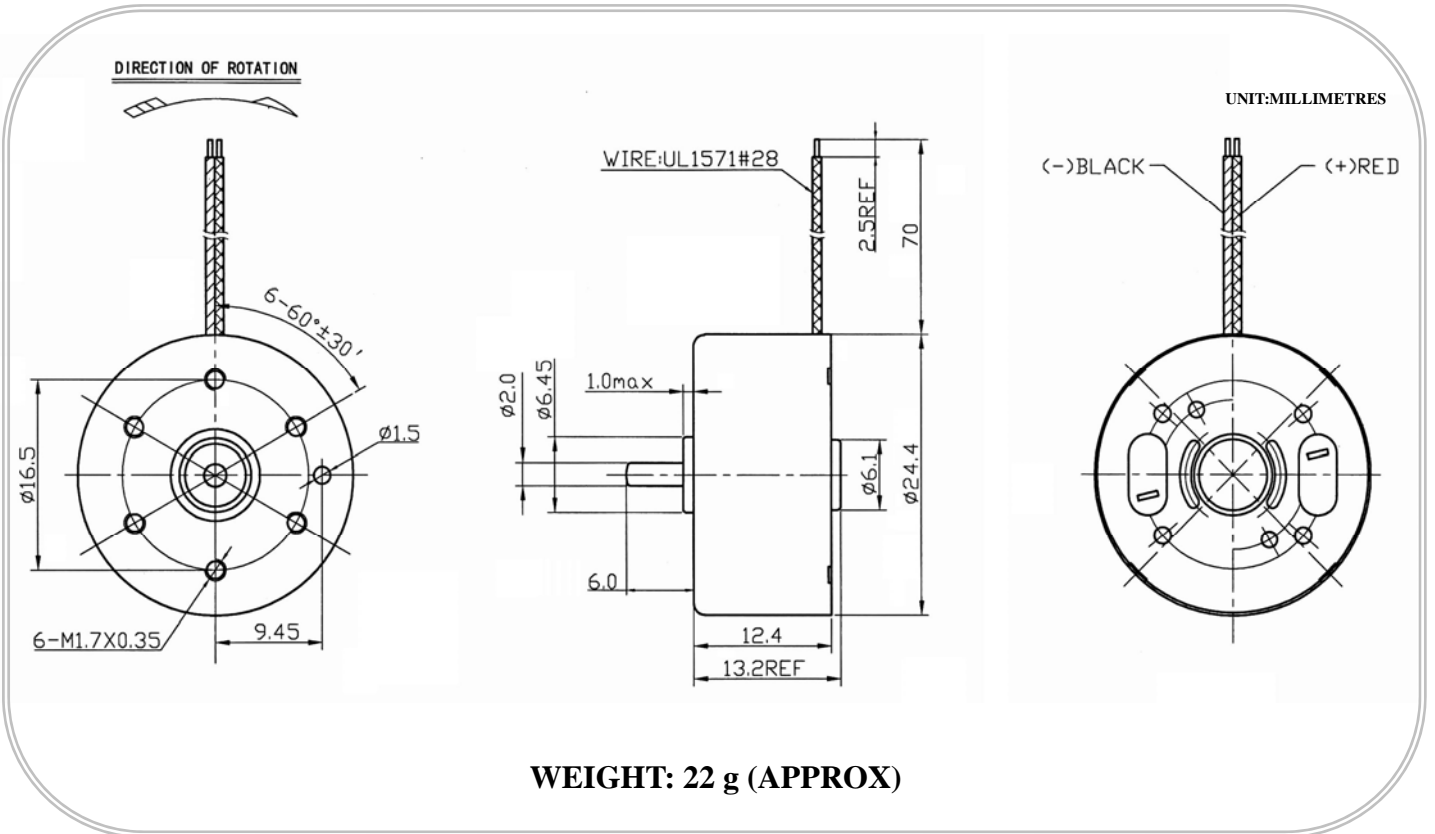

RF300 series

- Typical Applications:
- Office Automation Equipments
 - CD Rom
- Other Industrials
 - Air Freshener
 - Display
- Audio and Visual Equipment
- CD Player
 - Headphone Stereo
 - DVD Player



MODEL	VOLTAGE		NO LOAD		AT MAXIMUM EFFICIENCY				STALL		
	OPERATION RANGE	NOMINAL	SPEED	CURRENT	SPEED	CURRENT	TORQUE		TORQUE	CURRENT	
			rpm	A			mN-m	g-cm			mN-m
RF300-07615	3.0~6.0V	4.5V CONSTANT	3600	0.014	2688	0.041	0.29	3.0	1.18	12	0.12
RF300-11440	1.5~4.5V	3.0V CONSTANT	3500	0.026	2660	0.082	0.42	4.3	1.76	18	0.26
RF300-17190	1.5~3.0V	3.0V CONSTANT	8100	0.076	6530	0.311	0.74	7.5	3.82	39	1.29
RF300-15210	1.5~3.0V	4.5V CONSTANT	7350	0.060	5880	0.234	0.65	6.6	3.23	33	0.93