

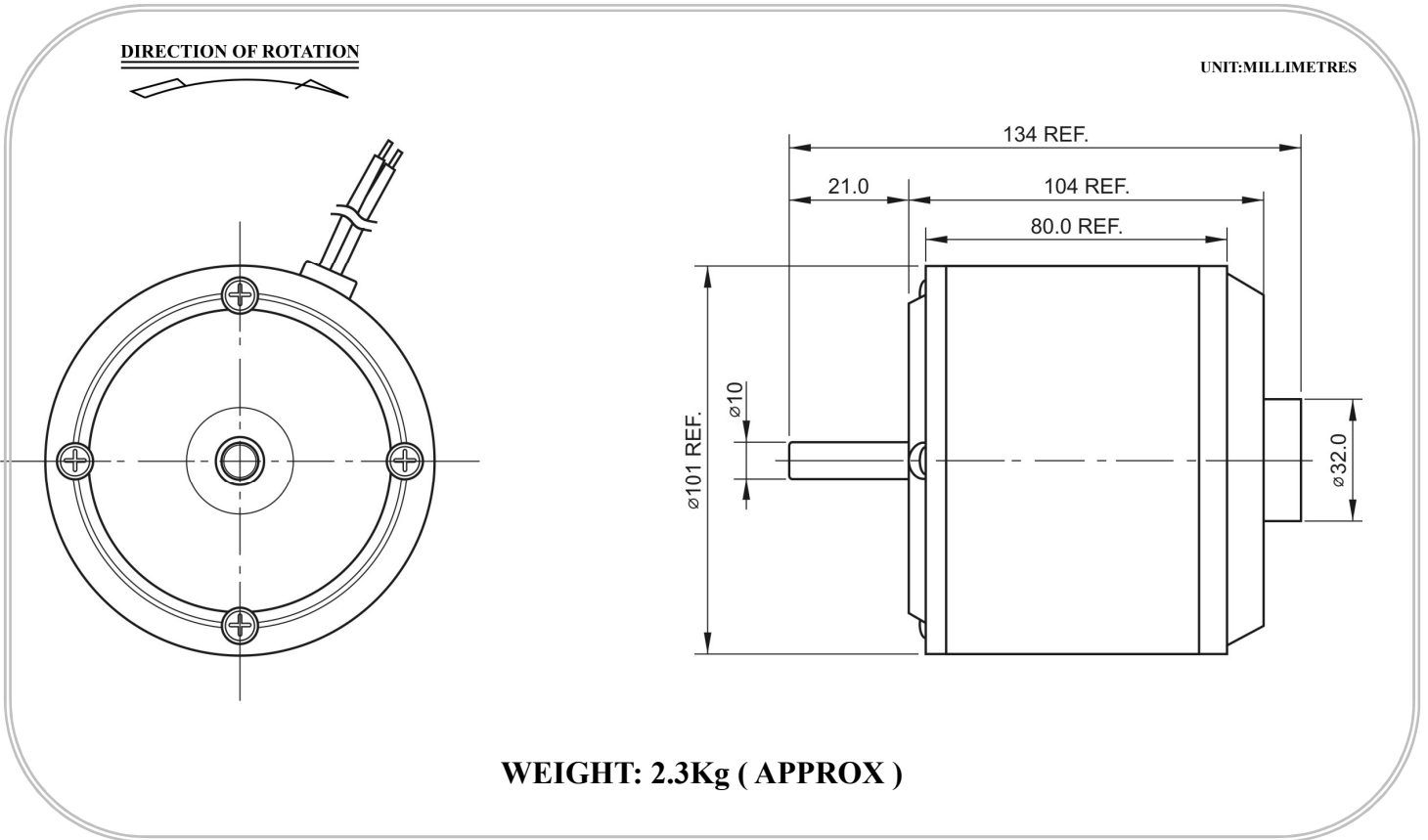

# TR101ESX Series

Typical Applications: Automotive Products  
 - Electric Scooter  
 - Automatic System Control



MODEL	VOLTAGE		NO LOAD		AT MAXIMUM EFFICIENCY				
	OPERATION RANGE	NORMAL	SPEED	CURRENT	SPEED	CURRENT	TORQUE		OUTPUT
			RPM	A	RPM	A	N-m	Kg-cm	W
TR101ES-X-24	15~30V	24V CONSTANT	3500±15%	2.5 Max	3000±15%	14.5 Max	0.64	6.5	200
TR101ES-X-24	15~30V	24V CONSTANT	4500±15%	3.0 Max	4000±15%	17.0 Max	0.64	7.8	310