

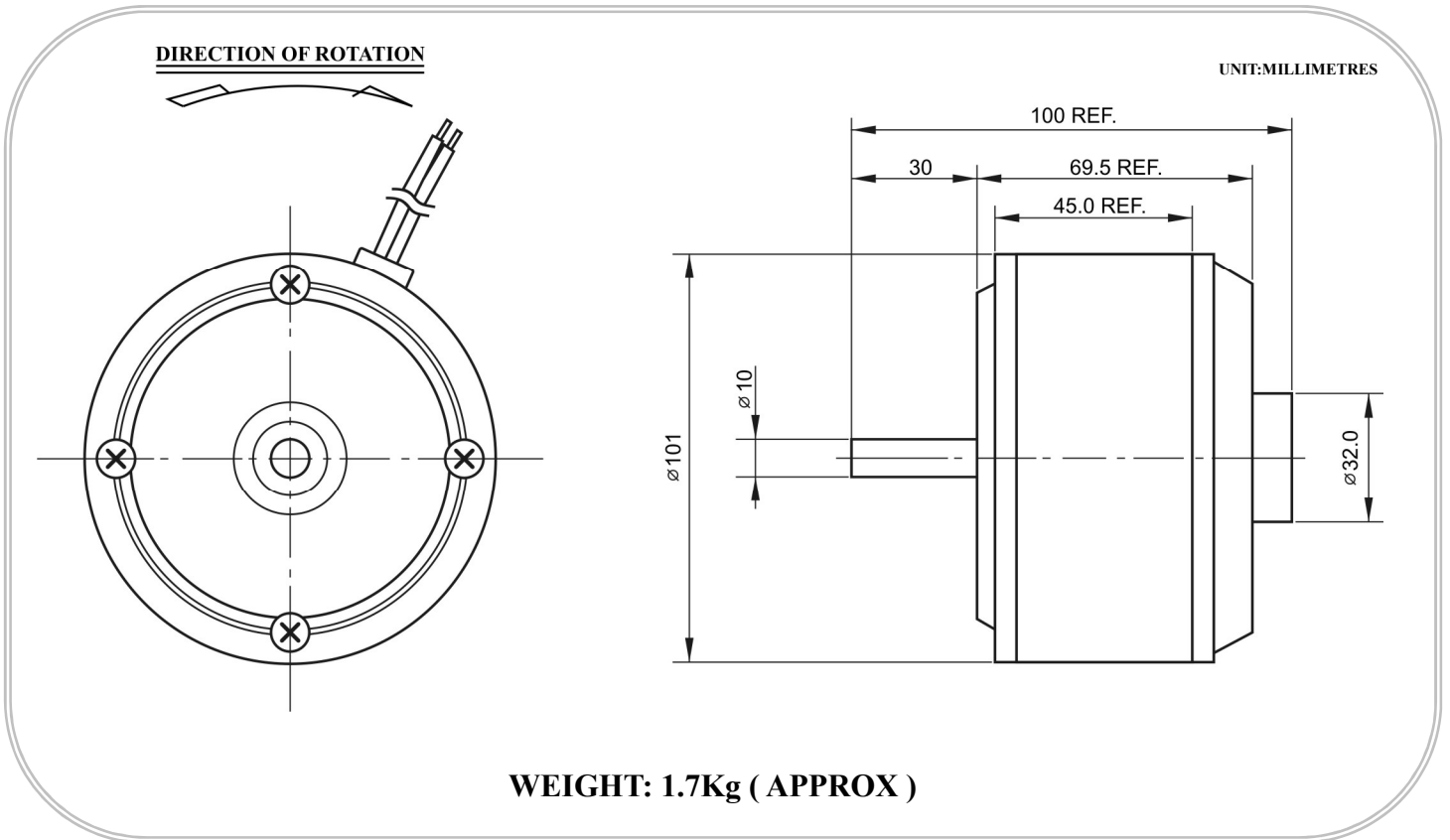

TR101ES Series

- Typical Applications:
- Automotive Products
 - Electric Scooter
 - Automatic System Control
 - Pump



MODEL	VOLTAGE		NO LOAD		AT MAXIMUM EFFICIENCY				STALL		
	OPERATION RANGE	NORMAL	SPEED	CURRENT	SPEED	CURRENT	TORQUE		TORQUE		CURRENT
			RPM	A	RPM	A	mN-m	Kg-cm	mN-m	Kg-cm	A
TR101ES-12	9.0~15V	12V CONSTANT	3130	2.2	2700	14.5	400	4.08	2000	20.41	55
TR101ES-24	18~28V	24V CONSTANT	3130	1.3	2700	8.0	410	4.18	2050	20.92	30