

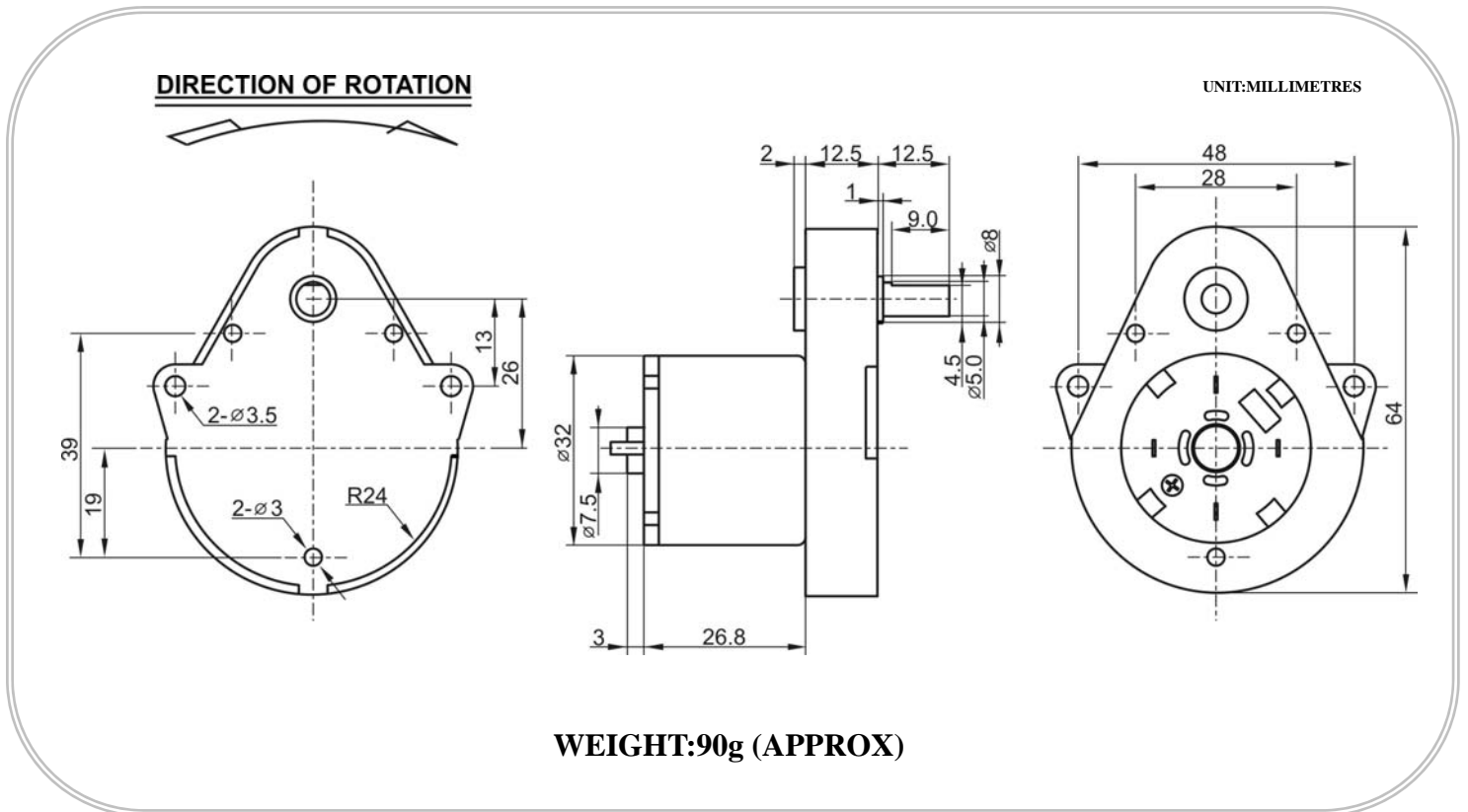

TR520-GM48 / TR528MC-GM48 series

Typical Applications Precision Instruments / Automotive Products
 - Household Appliances - Production Control System



MODEL	VOLTAGE		MOTOR	OUTPUT		STEP DOWN	MAXIMUM TORQUE	
	OPERATION RANGE	NOMINAL		SPEED	CURRENT		SPEED	N-m
			rpm	A	rpm	Ratio		
TR520-GM48	3.0~6.0V	6.0V CONSTANT	10000	0.4	540	19	0.39	4.00
TR528MC-GM48	3.0~6.0V	6.0V CONSTANT	10000	0.5	540	19	0.48	4.85