

# TF030-GA16 series

- Typical Applications
- Precision Instruments
  - Household Appliances
  - Production Control System

**DIRECTION OF ROTATION**

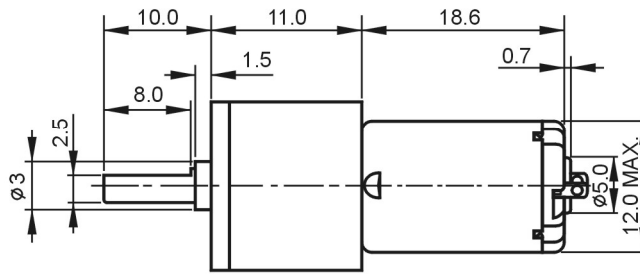
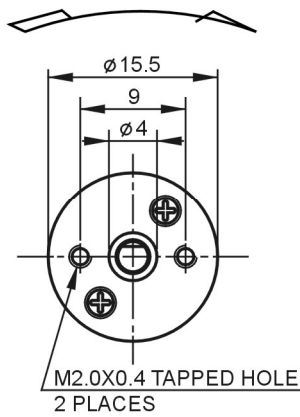

UNIT: MILLIMETRES

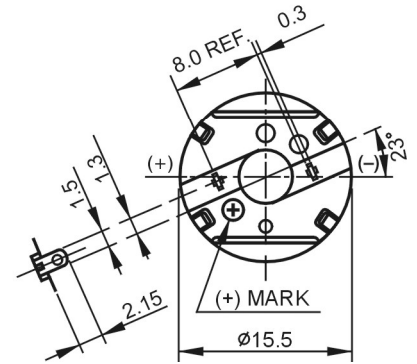

**WEIGHT: 18g (APPROX)**

MODEL	VOLTAGE		MOTOR SPEED rpm	OUTPUT		STEP DOWN Ratio	MAXIMUM TORQUE	
	OPERATION RANGE	NOMINAL		CURRENT A	SPEED rpm		mN-m	g-cm
TF030-08210-GA1635	1.5~6.0V	5.0V CONSTANT	9300	0.06	265	35	35.28	360