

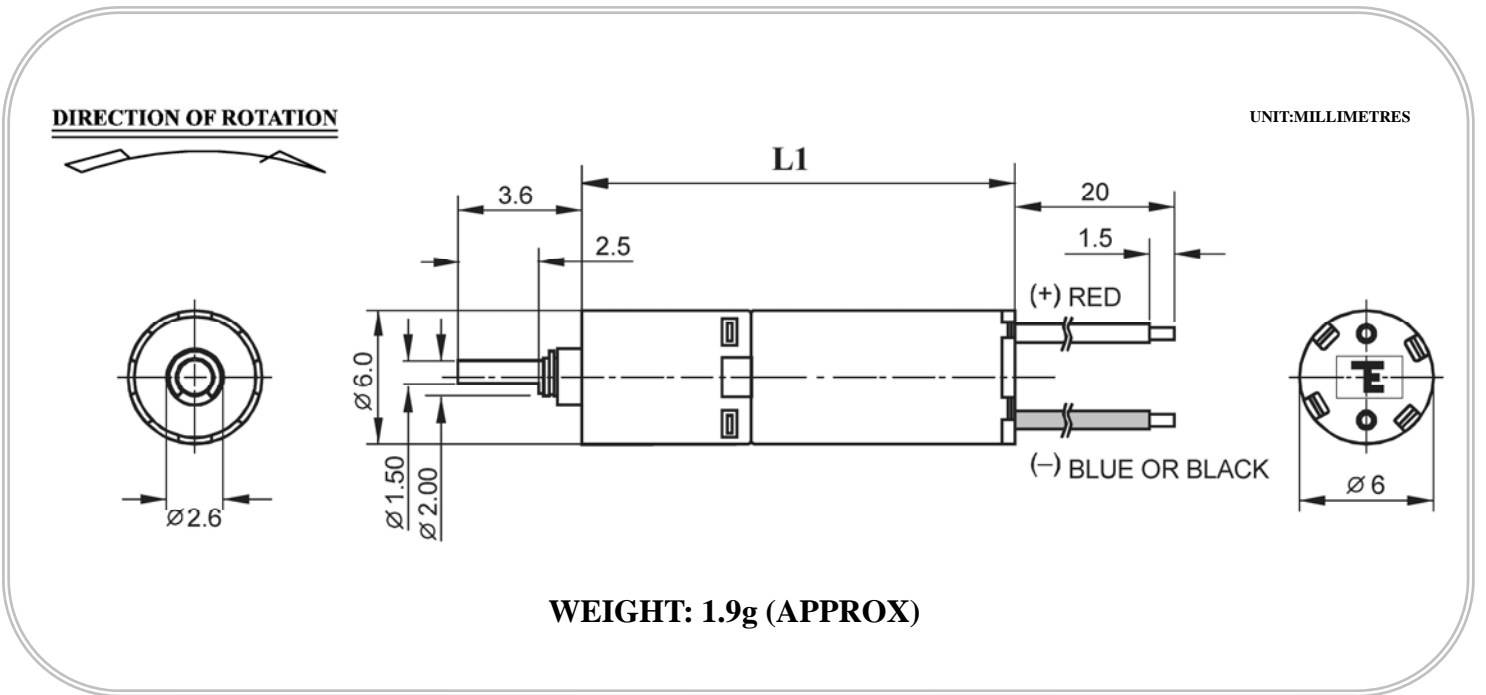

TCL610-GB series

- | | | |
|----------------------|-----------------------------|---------------------------|
| Typical Applications | Precision Instruments | Toys and Models |
| | - Household Appliances | - Electronic Game Machine |
| | - Production Control System | |



MODEL	VOLTAGE		MOTOR SPEED rpm (approx.)	OUTPUT		STEP DOWN Ratio (approx.)	Length L1 mm (approx.)	MAXIMUM TORQUE	
	OPERATION RANGE	NOMINAL		CURRENT A (Max)	SPEED rpm (approx.)			mN-m (approx.)	g-cm (approx.)
TCL610-GB26	2.5~5.0V	3.0V CONSTANT	31000	0.08	1000	26	16.35	2.45	25
TCL610-GB136	2.5~5.0V	3.0V CONSTANT	31000	0.08	200	136	18.70	11.76	120
TCL610-GB700	2.5~5.0V	3.0V CONSTANT	31000	0.08	40	700	21.07	19.60	200